



STRETCH WRAPPER  
MODEL: CSA 915

# CSA 915 Save your Time

Compact, high performance rotating arm machine for wrapping pallets with stretch film.

## Technical Characteristics

Total power installed	2.5 (kW)
Standard input voltage	400V three-phase - 50Hz - 6A
Protection on electric system & motors	IP 54
Max pallet dimensions	1000 x 1200 mm
Standard pallet height	2400 mm
Max capacity	1500 Kg
Maximum rotation speed	12 rpm
Production capacity per h	Up to 15
Operating pressure	6 bar pneumatic



- Optionals
- Inox version.
  - Acid protection.
  - Integrated weighing systems.
  - Mast for loads up to 3000 mm high.
  - Film weight check.
  - Pallet holder presser.
  - Roping system.

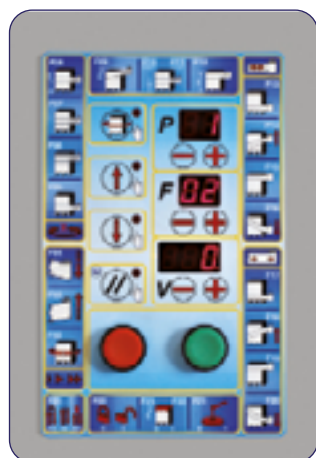
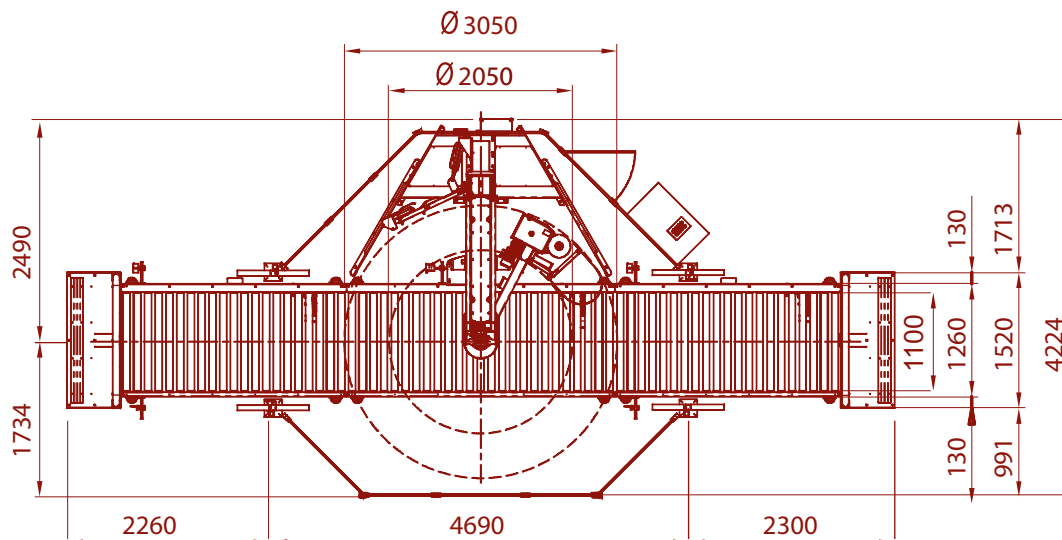

Control panel 99 programs easy-to-use.

## Save your Money

Motorized pre-stretch system with 3 driven rollers electronically controlled with interchangeable ratios: 150 - 200 - 250%.

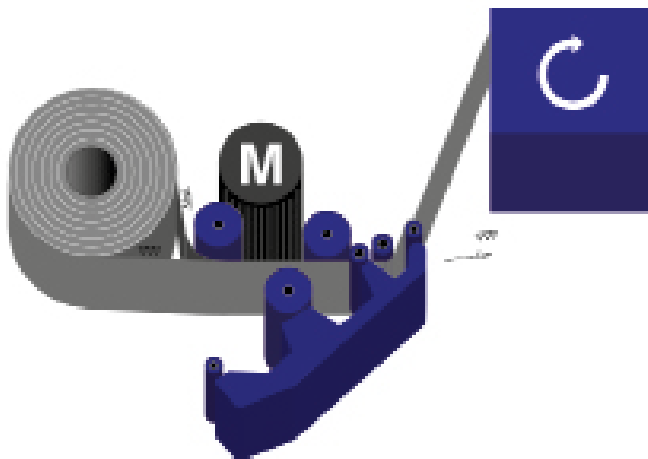

WWW.CYKLOP.NL  
+31 384675800

CYKLOP Nederland BV  
Benjamin Franklinstraat 5  
8013 NC Zwolle  
info@cyklop.nl

