



STRETCH WRAPPER  
MODEL: CSR TWIN

# CSR/CSR Twin Unbelievable

The only machine with external pre-stretch drive system, without electric sliding contacts/ slip rings or other complex and expensive solutions like electric generator. Available for output capacity up to 140 pallet /h. Also available with double reels.

## Technical Characteristics

Conveyor height std	500 mm +/- 50
Maximum ring rotation speed	65 rpm
Protection on electric system & motors	IP 54
Total power installed	12 Kw - 13 Kw with Top
Standard power supply	400V - 50 Hz - 3 PH+N+G
Operating pressure	6 bar
Pre-stretch ratio	Min. 160% - Max. 300%
Production capacity per h	Up to 120

## Product Dimensions

Max pallet dimensions	1200 x 1200 mm 1300 x 1100 mm
Min pallet dimensions	600 x 800 mm
Std pallet height	2200 mm

## Save your Money



External pre-stretch dry system.

- Optionals
- Acid protection.
  - For loads up to 3000 mm high.
  - Pallet holder presser.
  - Corner applicator.
  - Roping system.
  - Top cover.
  - Pallet lifter.
  - Jumbo reel.
  - Automatic change reel.

## Patented system

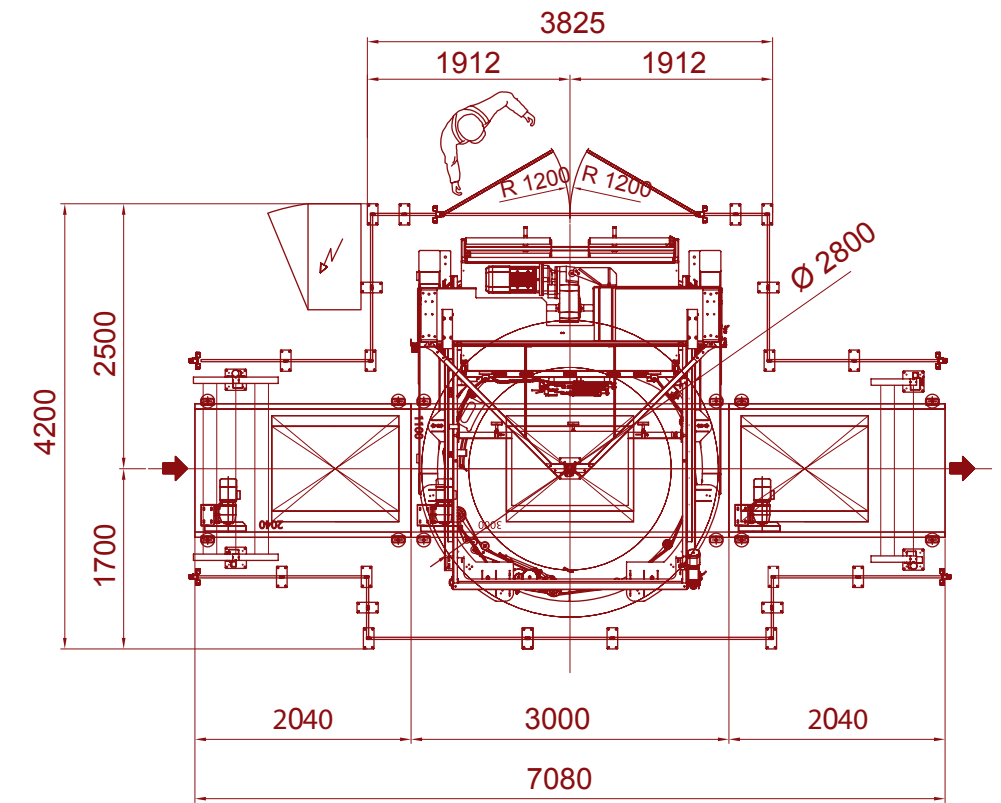

Control panel equipped in a standard version with a touch-screen operator Display.

140 pallet per hour

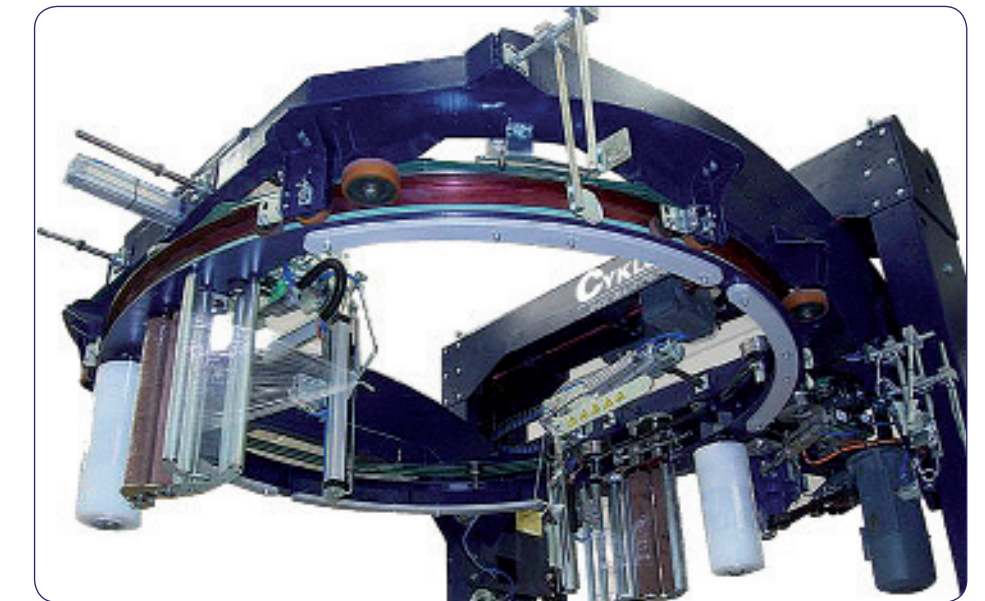

Double reels.

WWW.CYKLOP.NL  
+31 384675800

CYKLOP Nederland BV  
Benjamin Franklinstraat 5  
8013 NC Zwolle  
info@cyklop.nl

